

# R4045

ELECTRIC SCISSOR LIFT

SCISSOR LIFT



## KEY SPECS

### Platform Height

Indoor: 39-ft 3-in / 12-m  
Outdoor: 29-ft / 8.8-m

### Platform Capacity

Indoor: 770-lb / 350-kg  
Outdoor: 550-lb / 250-kg

### Number of Occupants

Indoor: 3  
Outdoor: 1

### Stowed Drive Speed

2.1 mph / 3.4 km/h

## KEY FEATURES

- Features narrow 45-in width, one of the narrowest widths in its class allowing for use in warehouse and distribution center aisles.
- Delivers a simplified, reliable design featuring our pothole protection system and fewer moving parts to reduce service calls.
- Built rugged for rentals, featuring an all-steel platform with steel component trays that allow professionals to meet the demands of the toughest job sites.
- Complies with A92.20 ANSI regulations, achieving the highest standards.

## ACCESSORIES & OPTIONS

- 4 x 6V AGM Batteries, 220 ah
- 900W Inverter
- Anti-Vandalism PKG
- CAN-Enabled Charger
- ClearSky™
- Coiled Platform Control Box Cable
- Drive Motor Covers
- Dual Flashing Amber Beacons - LED
- Eagle Performance Charger
- Flashing Amber Beacon - LED
- JLG® Mobile Control
- MDI (Ground)
- Panel Carrier
- Pipe Racks
- QuikFold Rails
- SkySense®
- USB Charger & Phone Holder
- White Noise Alarm

## STANDARD SPECIFICATIONS

Performance	Indoor	Outdoor
Platform Height (Elevated)	39-ft 3-in / 12-m	29-ft / 8.8-m
Platform Capacity	770-lb / 350-kg	550-lb / 250-kg
Capacity on Platform Extension	250-lb / 113-kg	250-lb / 113-kg
Number of Occupants	3	1
Lift / Lower Time (No Load)	68/41 seconds	68/41 seconds
Lift / Lower Time (Rated Load)	73/48 seconds	73/48 seconds
Maximum Drive Height	Fully Elevated	29-ft / 8.8-m
Weight*	7,000-lb / 3,175-kg	7,000-lb / 3,175-kg
Max. Ground Bearing Pressure	137 psi / 9.65 kg/cm <sup>2</sup>	137 psi / 9.65 kg/cm <sup>2</sup>
Drive Speed (Lowered)	2.1 mph / 3.4 km/h	2.1 mph / 3.4 km/h
Drive Speed (Raised)	0.5 mph / 0.8 km/h	0.5 mph / 0.8 km/h
Gradeability	25%	25%
Max Tilt Rating (Side-to-Side)	1.50 Degrees	1.50 Degrees
Max Tilt Rating (Fore and Aft)	3.50 Degrees	3.50 Degrees
Turning Radius (Inside)	Zero	Zero
Turning Radius (Outside)	100-in / 2.54-m	100-in / 2.54-m

\*Certain options or country standards increase weight

## Power

Batteries	4 x 12V 150 amp-hr
Charger	27 Amp
Drive	Hydraulic Front Wheel

## Tires

Standard	16 x 5-in / 406 x 127-mm
----------	--------------------------

## Brakes

Multi-Disc Friction

## Hydraulic System

Capacity	7.9 gal / 30 L
Pump	Fixed Displacement Gear

## STANDARD FEATURES

- 27 amp Multi-Function Universal Charger
- AC Receptacle in Platform
- Active Pothole Protection System
- All Motion Alarm
- Analyzer Port for Diagnostics
- Battery Condition Indicator
- Diamond Tread Steel Deck
- Dynamic Braking
- Foot-Actuated Deck Extension
- Fork Lift Pockets
- Greaseless Kingpin Joints
- Horn
- Hourmeter
- Lanyard Attach Points
- Lifting and Tie Down Points
- Load Sensing System
- Lubrication Free Scissor Arm Bushings
- Manual Descent Cable
- Movable, Removable Platform Control
- Nickel Plated Pins
- Proportional Controls
- Removable Ladder
- Scissor Maintenance Prop
- Self-Closing Gate
- Steel Swing-Out Doors
- Tilt Alarm and Light
- Variable Tilt Visual Zone Indicator

# R4045

## ELECTRIC SCISSOR LIFT

SCISSOR LIFT



### DIMENSIONS

All dimensions are approximate

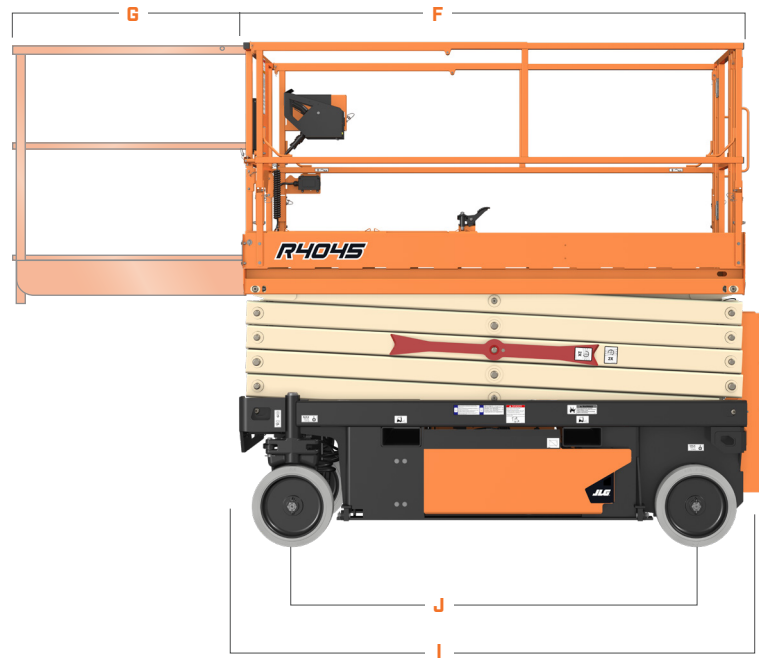
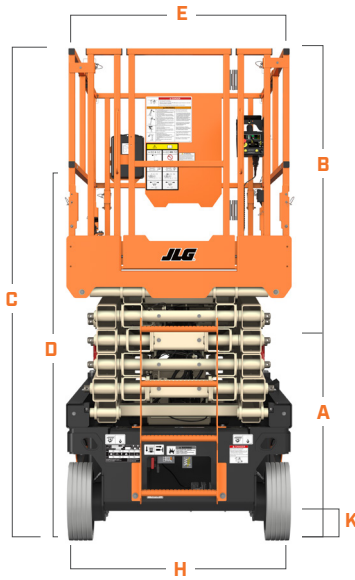

- A.** Platform Height (Lowered) 55.0-in / 1.4-m
- B.** Platform Railing Height 44-in / 1.132-m
- C.** Machine Height (Rails Raised) 100-in / 2.53-m
- D.** Machine Height (Rails Lowered) 75-in / 1.9-m
- E.** Platform Width 41-in / 1.05-m
- F.** Platform Length 96-in / 2.43-m
- G.** Platform Extension 36-in / 91-cm

- H.** Machine Width 45-in / 114.3-cm
- I.** Machine Length 106-in / 2.71-m
- J.** Wheelbase 80-in / 2.03-m
- K.** Ground Clearance 5-in / 12.7-cm



We provide coverage for one (1) full year, and cover all specified major structural components for five (5) years. Due to continuous product improvements, we reserve the right to make specification and/or equipment changes without prior notification. This machine meets or exceeds applicable ANSI and CSA requirements based on machine configuration as originally manufactured for intended applications. Please reference the serial number plate on the machine for additional information.



**JLG INDUSTRIES, INC.**  
Toll-free US 877-JLG-LIFT  
[JLG.com](http://JLG.com)

An Oshkosh Corporation Company