

1,000kg Passenger & Goods Hoist

MACHINE SPECIFICATION SHEET

PG500P5-IT

MAX HEIGHT	100.00m
LIFTING CAPACITY	1,000kg
PERSON CAPACITY	5 PERSONS / 500kg
CAGE DIMENSIONS	1.60 x 1.40m
LIFT SPEED	12 m/min / 24 m/min
POWER	ELECTRIC 3 kW / 6.1 kW / 400 V / 50 Hz / 16 A
FEATURED MODEL	GEDA 500ZZP

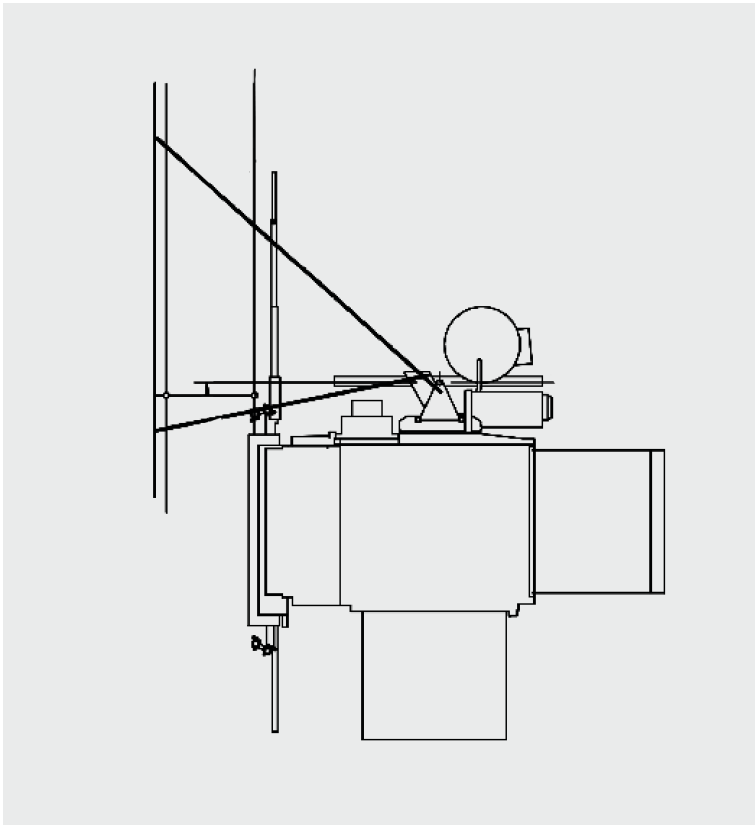

Rapid Hoists are a national service provider for construction hoists available across the UK, offering one of the newest fleets in the UK along with its program of investment means we can rapidly respond to any of your needs.

The GEDA 500 Z/ZP transport platform is designed for tough construction sites, offering flexibility. It can be used for materials or passengers with fast speeds (24 m/min material, 12 m/min passenger). It's essential for scaffolding assembly and construction work, saving time and optimizing logistics. It offers various versions for site-specific adaptation, including a spacious loading platform.

The information provided is for guidance only. It may change at any time in accordance with manufacturer's specification.



t 01279 501501

e info@rapidplatforms.co.uk