

# 500kg Goods Hoist



Rapid Hoists are a national service provider for construction hoists available across the UK, offering one of the newest fleets in the UK along with its program of investment means we can rapidly respond to any of your needs.

The 500Z is a large double barrow hoist suitable for lifting equipment and materials only.

Geda hoists are strong and durable goods lifts that can be wall-mounted or attached directly to scaffolding. Electric hoist rental with Rapid Platforms includes the installation and disassembly of equipment.

## MACHINE SPECIFICATION SHEET

### G500

MAX HEIGHT	100.00m
LIFTING CAPACITY	500kg
PERSON CAPACITY	GOODS ONLY
CAGE DIMENSIONS	1.60 x 1.40m
LIFT SPEED	30.00m/min
POWER	ELECTRIC 400v 16a 50Hz
FEATURED MODEL	GEDA 500Z
ALTERNATIVE MODELS	MABER MB500 GEDA 500 Z F

The information provided is for guidance only. It may change at any time in accordance with manufacturer's specification.

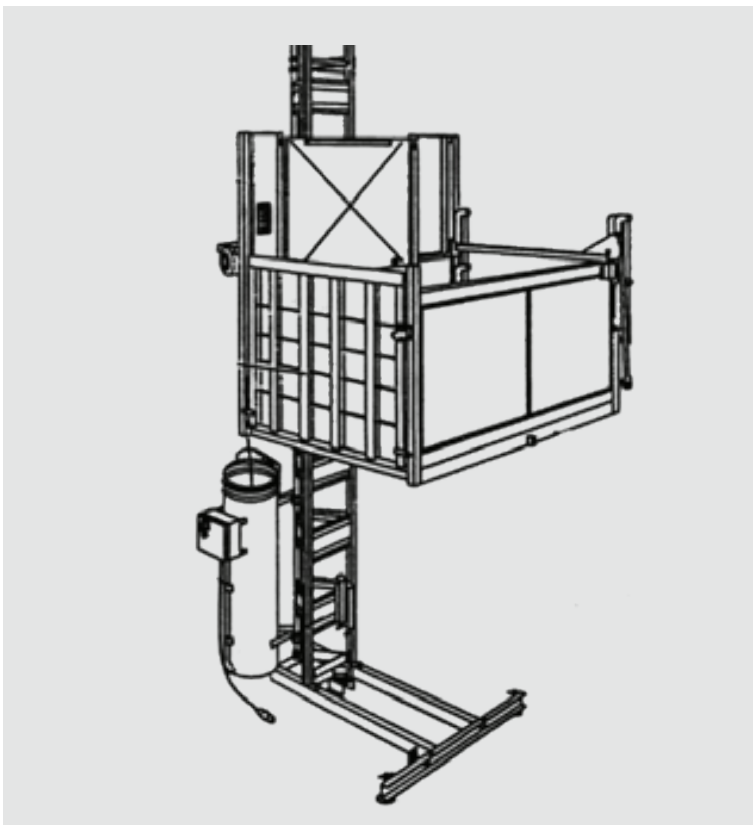

**t 01279 501501**

**e [info@rapidplatforms.co.uk](mailto:info@rapidplatforms.co.uk)**